

V-Kart 400 E

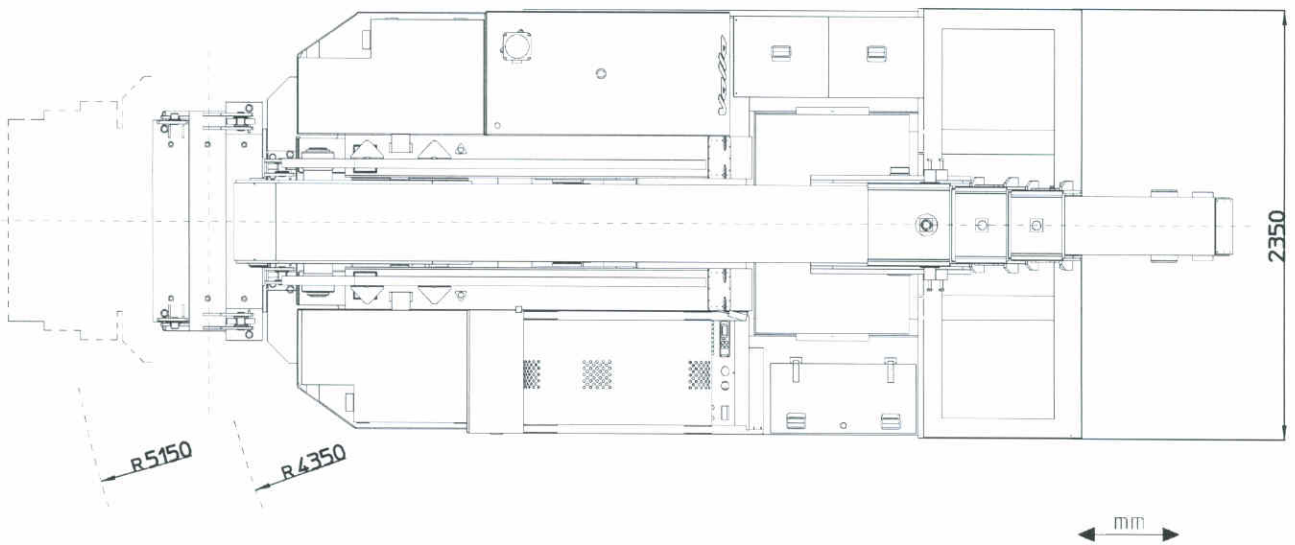

V-Kart 400 E

Antriebseinheit eingefahren

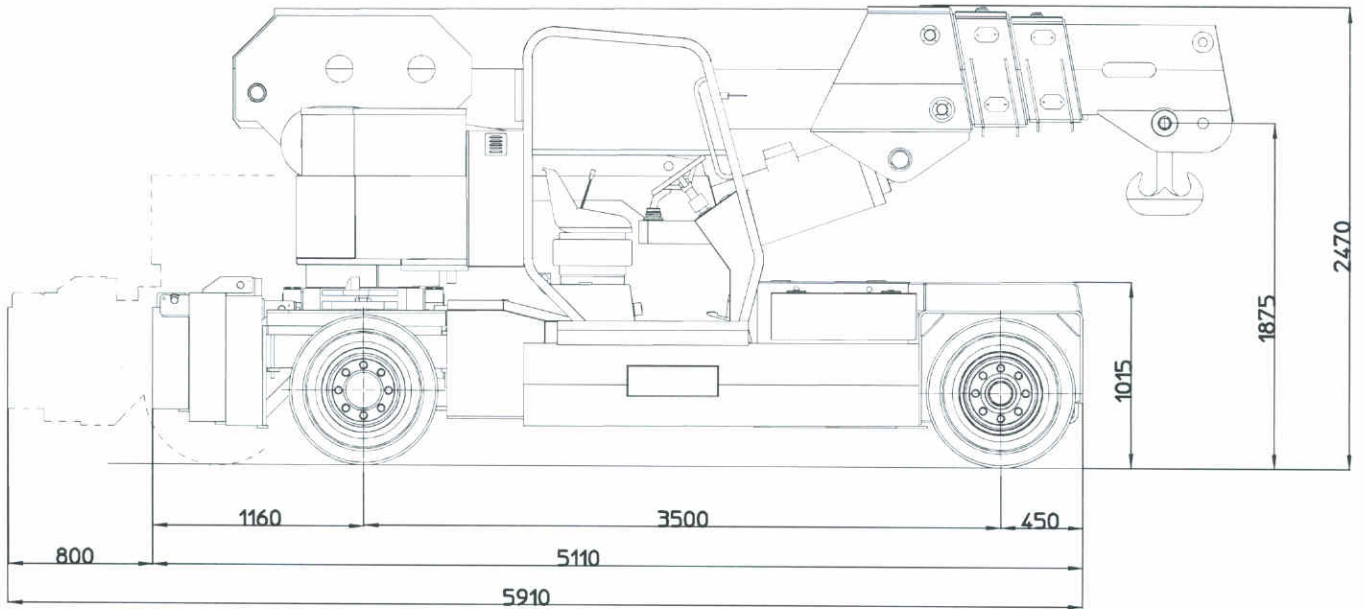
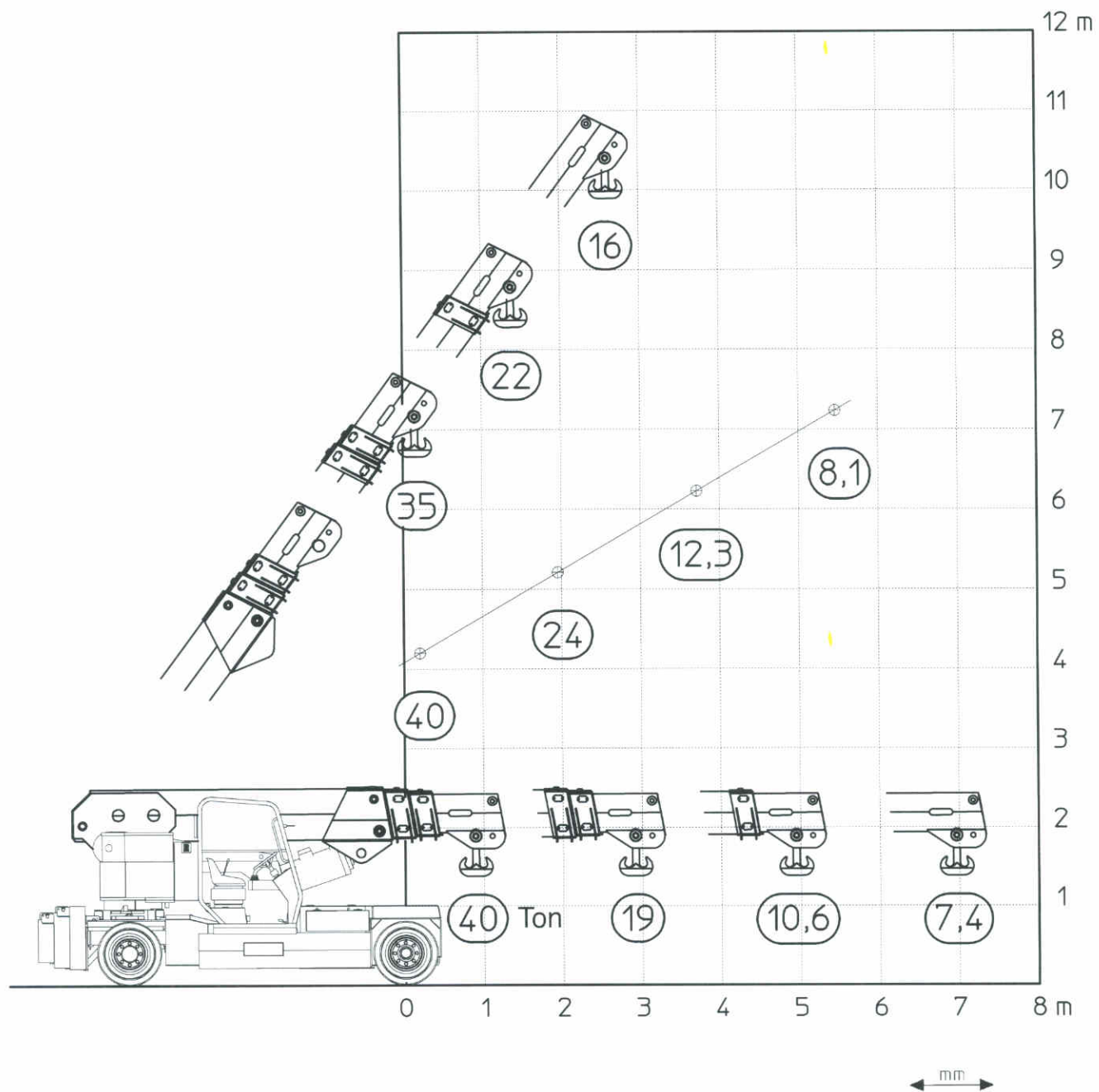

V-Kart 400 E

Antriebseinheit ausgefahren

The crane complies with following international standards:
 - I.S.P.E.S.L.
 - DIN 15018 (1,3) - 15019 (1) class H 2 B3
 - ANSI - 1994
 - 98/37/CE
 - 89/336/CEE

